

GL34A THRU GL34M

Silicon passivated type

Features

- Plastic package has Underwriters Laboratory Flammability Classification 94V-O Utilizing Flame Retardant Epoxy Molding Compound.
- For surface mounted applications.
- Exceeds environmental standards of ML-S-19500 / 228
- Low leakage current

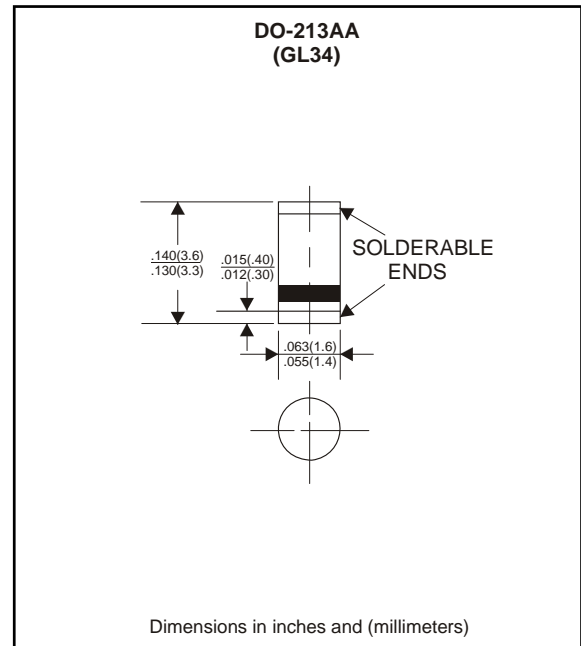

Mechanical data

Case : Molded plastic, JEDECDO-213AA
 Terminals : Solder plated, solderable per ML-STD-750, Method 2026
 Polarity : Indicated by cathode band
 Mounting Position : Any
 Weight : 0.036 gram

MAXIMUM RATINGS (AT $T_A=25^{\circ}C$ unless otherwise noted)

PARAMETER	CONDITIONS	Symbol	MIN.	TYP.	MAX.	UNIT
Forward rectified current	See Fig.1	I_0			0.5	A
Forward surge current	8.3ms single half sine-wave superimposed on rate load (JEDEC methode)	I_{FSM}			10	A
Reverse current	$V_R = V_{RRM} T_A = 25^{\circ}C$	I_R			5.0	μA
	$V_R = V_{RRM} T_A = 125^{\circ}C$				250	μA
Thermal resistance	Junction to ambient	$R_{\theta JA}$		125		$^{\circ}C / w$
Diode junction capacitance	$f=1MHz$ and applied 4vDC reverse voltage	C_J		4.0		pF
Storage temperature		T_{STG}	-55		+125	$^{\circ}C$

SYMBOLS	MARKING CODE	V_{RRM}^{*1} (V)	V_{RMS}^{*2} (V)	V_R^{*3} (V)	V_F^{*4} (V)	Operating temperature ($^{\circ}C$)
GL34A	-	50	35	50	1.1	-55 to +125
GL34B	-	100	70	100		
GL34D	-	200	140	200		
GL34G	-	400	280	400		
GL34J	-	600	420	600		
GL34K	-	800	560	800		
GL34M	-	1000	700	1000		

*1 Repetitive peak reverse voltage

*2 RMS voltage

*3 Continuous reverse voltage

*4 Maximum forward voltage

RATING AND CHARACTERISTIC CURVES (GL34A THRU GL34M)

FIG.1-TYPICAL FORWARD CURRENT DERATING CURVE

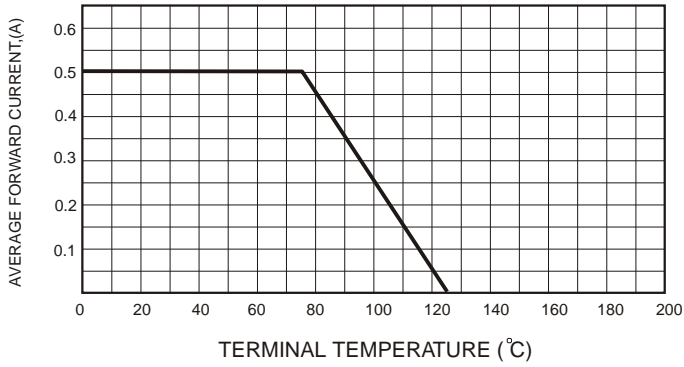

FIG.2-TYPICAL FORWARD CHARACTERISTICS

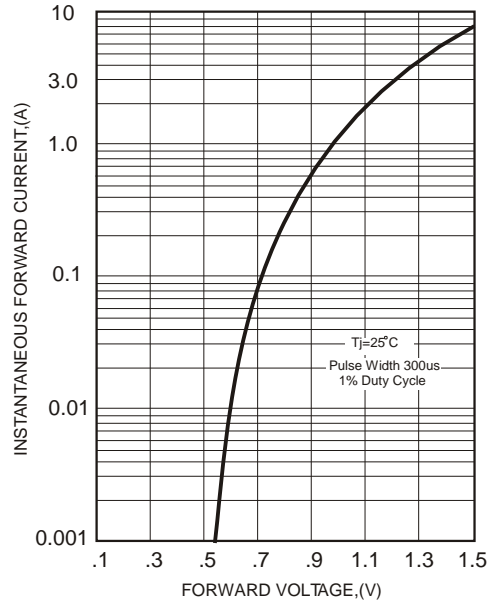

FIG.3-MAXIMUM NON-REPETITIVE FORWARD SURGE CURRENT

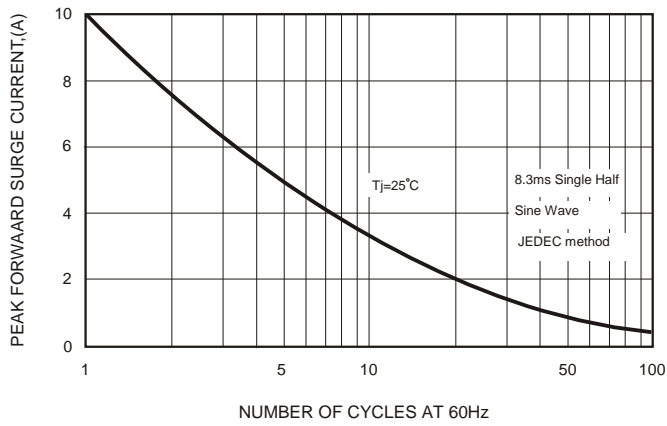

FIG.5 - TYPICAL REVERSE CHARACTERISTICS

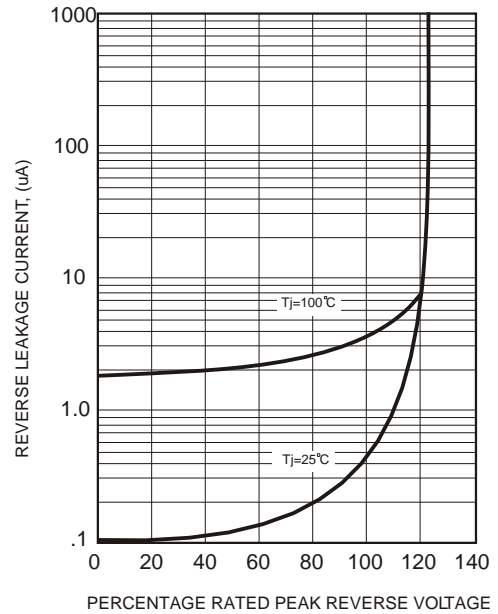

FIG.4-TYPICAL JUNCTION CAPACITANCE

